

A NEW PROFILE FOR THE COMPACT CART

compact-cart

The **compact-cart** equipment carrier has been successfully established in the market for many years. ITD GmbH has made some major changes in the new version incorporating the base, power supply, cable management and design. These changes represent a swift response to the continually changing demands of the marketplace.



new

Power supply – high-performance and safe

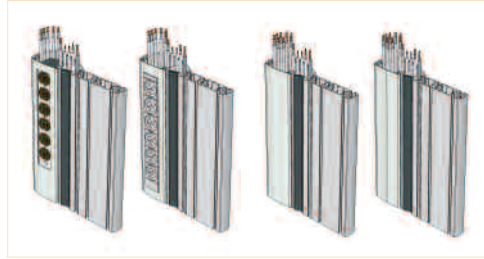

The new power column now accommodates all standard **socket strips**, e.g. hospital grade, along the entire length of the extrusion, without any compromises on the number of sockets. It also offers protection against unauthorized access and virtually invisible cable management.



Integration of **powerful transformers** up to 2000 VA is already possible from an equipment cart width of 450 mm.



The central **on / off switch** is clearly visible, accessible at any time and protected in the energy column.

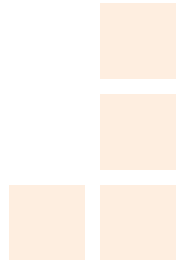

Cable management – sophisticated, direct and virtually invisible

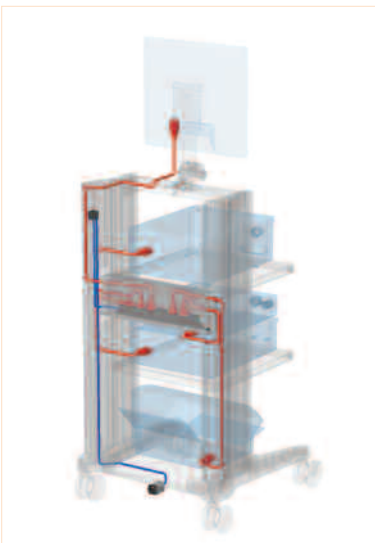

The **central power supply** optionally mounted in the equipment cart combines with the power columns to permit concealed and direct cabling to individual items of equipment, accommodate socket strips and offer protection against unauthorized access.



Soft rubber seals permit cable entry and exit along the length of the energy column.



A NEW PROFILE FOR THE COMPACT CART

Base – space-saving, robust and compact

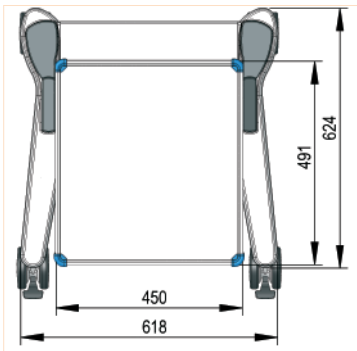

The new design for the base delivers an optimum ratio between platform and work area in **compact-cart**. Stability is guaranteed, even with high payloads weighing up to 180 kg.

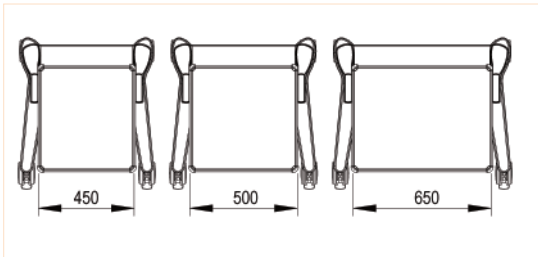

The **compact-cart** base is available in widths of 450, 500 and 650 mm, and in standard heights of 30U, 35U and 40U (1 U = 32 mm).

Design – adaptable, ergonomic and modern

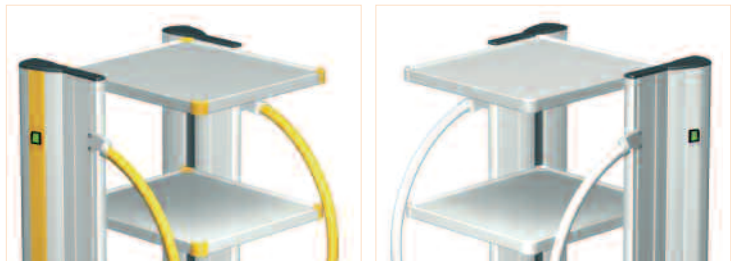

Handles, corners and decorative trims in the power column are design interfaces and colours can be adapted to match the equipment or the corporate CD. They are available as standard colour schemes in the three colours RAL 7035 light grey, RAL 5015 sky blue and RAL 1003 signal yellow.

A NEW PROFILE FOR THE COMPACT CART

compact-cart

Accessories – modular, comprehensive and matching any requirement

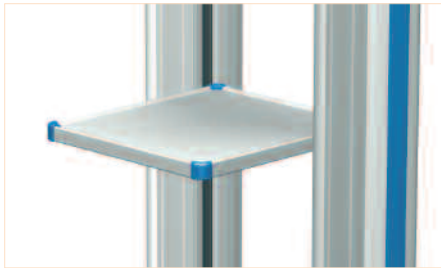

The shelf is supplied with a handle and mouse pad, as well as offering a continuous raised edge to provide a safe platform for equipment. Rounded corners prevent injuries.

Load capacity: 50 kg / 110 lbs



The drawer is supplied in different versions and can be delivered as a lockable version on request. Roller-guided, self-retracting steel runners make the drawer easy to slide in and out.

Load capacity: 5 kg / 11 lbs

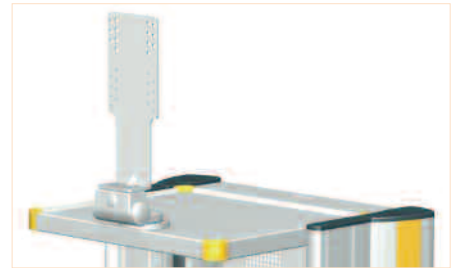

The monitor holder mounted on the shelf can be swivelled, permits a tilt angle of $\pm 15^\circ$ and is suitable for monitors with VESA 75 / 100 and VESA 200 / 300 adaptors.

Load capacity: 14 kg / 30.8 lbs

Facts, figures, and data

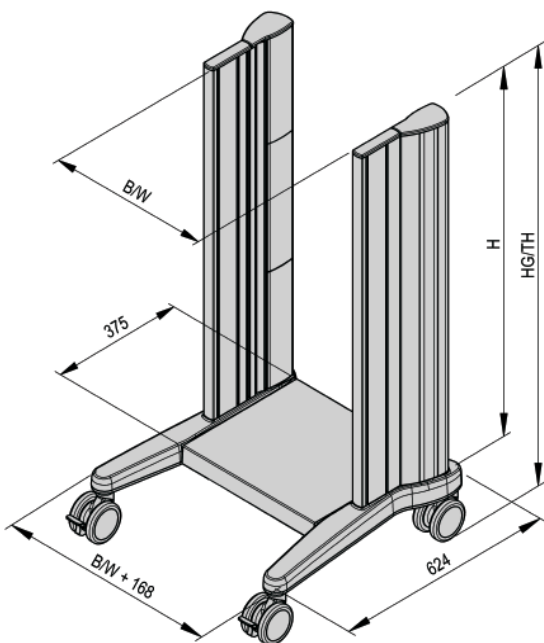

Installation height	L-shaped columns = H	TH for castors Ø 100	TH for castors Ø 125
30 U	960 mm	1146 mm	1171 mm
35 U	1120 mm	1306 mm	1331 mm
40 U	1280 mm	1466 mm	1491 mm

Installation width W	Total width TW
450 mm	618 mm
500 mm	668 mm
650 mm	818 mm

The base is fitted with:

- 1 base frame
- 4 twin swivel castors Ø 100 mm (optionally: Ø 125 mm), with 2 lockable castors
- 2 vertical extrusions, each with 2 threaded strips
- 2 power columns with caps and cover strips

Load capacity: 180 kg / 396 lbs



ITD GmbH
 Grünwalder Weg 13a · 82008 Unterhaching · Germany
 Tel. +49-89-61 44 25-0 · Fax +49-89-61 44 25-20
 e-mail: sales@itd-cart.com · www.itd-cart.com